

Arco_470

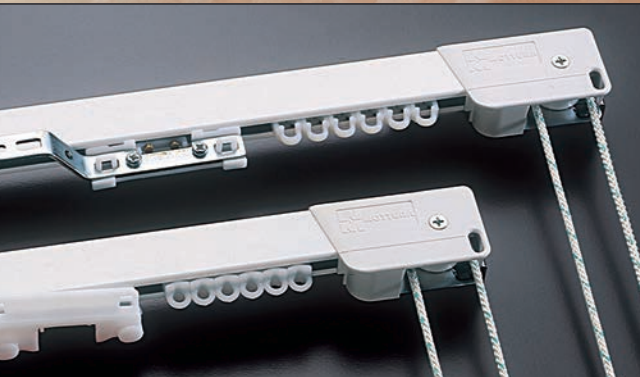

1:1

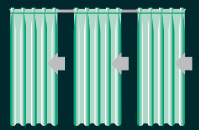
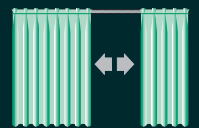
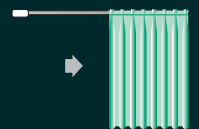
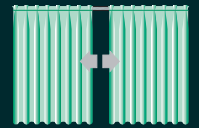
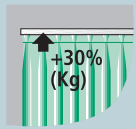
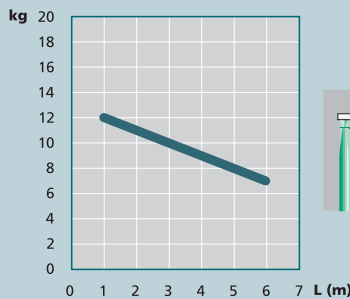
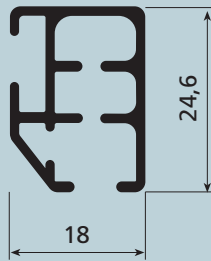

USE

UTILIZZO - USE - USO
USO - UTILISATION - ANWENDUNG
GEBRUIK - ИСПОЛЬЗОВАНИЕ

SISTEMA PER TENDE ARRICCIATE INDICATO PER AMBIENTI DOMESTICI E PROFESSIONALI

Azionamento con corde. Indicato per tendaggi L 600 cm max ed H 400 cm di peso non superiore a 7 kg con scivoli (12 kg con scorrevoli).

L'apertura della tenda può essere centrale, laterale, multipla o asimmetrica.

Il sistema è indicato per installazioni a soffitto ed a parete.

Lo scorrimento delle corde d'azionamento in canali indipendenti paralleli permette la realizzazione di sistemi curvi a 90° o centinati ad ampio raggio, garantendo un'ottima scorrevolezza.

Lo scorrimento è garantito da scivoli autolubrificanti in polietilene o da scorrevoli a rulli per i tendaggi al limite della portata.

DRAPED CURTAIN SYSTEM SUITABLE FOR DOMESTIC AND PROFESSIONAL ENVIRONMENTS

Cord operated. For use with curtains 600 cm W max. and 400 cm H weighing not more than 7 kg with slides (12 kg with gliders).

The curtain opening can be central, lateral, multiple or asymmetric.

The system is suitable for ceiling and wall installations.

The running of the operating cords in independent channels allows systems with 90° curves or with wide radius centring to be installed, guaranteeing excellent sliding.

Sliding is guaranteed by self-lubricating polyethylene slides or by roller gliders for curtains at the load limit.

SISTEMA DE CORTINAS FRUNCIDAS ADECUADO PARA AMBIENTES DOMÉSTICOS Y PROFESIONALES

Accionamiento mediante cordones. Indicado para cortinas de anchura máx. 600 cm y altura máx. 400 cm y de peso hasta 7 kg con correderas (12 kg con correderas de ruedas).

La apertura de la cortina puede ser central, lateral, múltiple o asimétrica.

Este sistema es indicado para montajes tanto en techo como en pared.

El deslizamiento de los cordones de accionamiento en canales independientes permite realizar instalaciones curvas en 90° o curvas de amplio ángulo, garantizando una óptima deslizabilidad. El deslizamiento se efectúa mediante correderas deslizantes autolubricadas de polietileno o correderas de ruedecillas para las cortinas más pesadas.

SISTEMA PARA CORTINAS FRANZIDAS INDICADO PARA AMBIENTES DOMÉSTICOS E PROFISSIONAIS

Accionamento com cordões. Indicado para cortinas com largura máxima de 600 cm, altura 400 cm e peso não superior a 7 kg com deslizadores (12 kg com corrediças).

A abertura da cortina pode ser central, lateral, múltipla ou assimétrica.

Este sistema é indicado para instalações no tecto e na parede.

O deslizamento dos cordões de accionamento em canais paralelos independentes permite instalar sistemas com curvas de 90° ou curvaturas de raio amplo, garantindo uma óptima fluidez no movimento de deslizamento. O deslizamento é garantido por deslizadores de polietileno autolubrificantes ou por corrediças de rolos para cortinas no limite máximo de peso.

SYSTÈME POUR RIDEAUX DRAPÉS POUR LOCAUX DOMESTIQUES OU PROFESSIONNELS

Actionnement par drisses. Conseillé pour rideaux L 600 cm max. et H 400 cm d'un poids maximum de 7 kg avec glisseurs (12 kg avec rouleurs).

L'ouverture du rideau peut être centrale, latérale, multiple ou asymétrique. Ce système est indiqué pour installations au plafond et de face.

Le coulissement des drisses d'actionnement en rails indépendants superposés permet la réalisation de systèmes courbés à 90° ou cintrés à grand rayon, garantissant un excellent coulissement.

Le coulissement est assuré par glisseurs autolubrifiants en polyéthylène ou par rouleurs pour les rideaux atteignant le poids maximum.

VORHANGSYSTEM FÜR DEN PRIVATEN HAUSHALT UND DEN ARBEITSBEREICH

Schnurbetätigung. Für Gardinen mit max. L 600 cm und H 400 cm, Gewicht höchstens 7 kg, mit Gleitern (12 kg mit Roller).

Mögliche Öffnungsarten: 2-teilig, einteilig, mehrteilig oder asymmetrisch.

Das System ist für Decken- und Wandmontage geeignet.

Durch das Gleiten der Betätigungsschnüre in unabhängigen, übereinanderliegenden Kanälen können im 90°-Winkel gebogene Systeme oder Systeme mit großem Radius ausgeführt werden.

Selbstschmierende Polyethylengleiter und Rollgleiter für Gardinen, deren Gewicht fast an der Tragfähigkeitsgrenze liegt, gewährleisten einwandfreies Gleiten.

GORDIJSYSTEEM VOOR PRIVAAT EN PROFESSIONEEL GEBRUIK

Koordbediend. Te gebruiken voor gordijnen van maximum 600 cm breed en 400 cm hoog, met maximum gewicht van 7 kg met glijders en 12 kg met rollers.

Pakket: centraal, lateraal, meervoudig of asymmetrisch.

Het systeem kan tegen de wand of tegen het plafond geplaatst worden.

De koorden bevinden zich in aparte koordkanalen, waardoor de rail op 90° of op grote straal kan worden verbogen.

Het glijden is gegarandeerd door zelfsmerende polyethyleenglijders of door rollers voor gordijnen aan het limietgewicht.

СИСТЕМА ДЛЯ ДРАПИРОВАННЫХ ШТОР, РЕКОМЕНДУЕТСЯ ДЛЯ БЫТОВЫХ И ОФИСНЫХ ПОМЕЩЕНИЙ

Приведение в действие шнурами. Рекомендуется для штор Д. 600 см макс. и В. 400 см с весом не более 7 кг с ползками (12 кг с бегунками).

Открытие штор может быть центральным, боковым, в нескольких точках и несимметричным. Эта система рекомендуется для потолочных и настенных установок. Движение шнуров по параллельным независимым желобам позволяет выполнять системы с поворотом 90° или с большим радиусом, обеспечивая отличную подвижность.

Движение осуществляется посредством самосмазывающихся ползков из полиэтилена или роликовых бегунков для штор, вес которых приближается к максимальному.



1.1.10

Arco_470



CARATTERISTICHE TECNICHE - SPECIFICATIONS CARACTERÍSTICAS - CARACTERÍSTICAS - CARACTÉRISTIQUES EIGENSCHAFTEN - KARAKTERISTIEKEN - ХАРАКТЕРИСТИКИ

- Profilo in lega d'alluminio estrusa 6060 T6 UNI 8278
- Larghezza 18 mm - Altezza 24,6 mm
- Canale di scorrimento: 6 mm
- Raggio di curvatura minima curve a 90°: 12 cm
curve ad ampio raggio: 50 cm
- Finiture superficiali:
verniciatura poliester bianco RAL 9016
verniciatura poliester nero RAL 9005 - anodizzato argento
- Carrucole in termoplastico antiurto con ruote su perni in acciaio
- Sormonto in acetilica autolubrificante da 7 cm
- Accessori in acetilica autolubrificante

- 6060 T6 UNI 8278 extruded aluminium alloy track
- Width 18 mm - Height 24,6 mm
- Sliding channel: 6 mm
- Minimum radius of curvature 90° curves: 12 cm wide radius
curves: 50 cm
- Surface finishes: RAL 9016 white polyester paint RAL 9005 black
polyester paint; silver anodised
- Shockproof thermoplastic pulleys with wheels on steel journals
- 7 cm self-lubricating acetylic overlap
- Self-lubricating acetylic accessories

- Perfil en aleación de aluminio extruido 6060 T6 UNI 8278
- Anchura 18 mm - Altura 24,6 mm - Canal de deslizamiento: 6 mm
- Radio de curvatura mínima:
curvas en 90°: 12 cm; curvas de ángulo amplio: 50 cm
- Acabados de la superficie:
pintura poliéster blanca RAL 9016 - pintura poliéster negra
RAL 9005; anodizado plata
- Polea de termoplástico endurecido con ruedas sobre ejes
de acero
- Sobreposición de acetálico autolubrificante de 7 cm
- Accesorios de acetálico autolubrificante

- Perfil de liga de alumínio extrudido 6060 T6 UNI 8278
- Largura 18 mm - Altura 24,6 mm
- Calha de deslizamento: 6 mm
- Raio de curvatura mínimo curvas de 90°: 12 cm
curvas de raio amplo: 50 cm
- Acabamentos superficiais:
tinta de poliéster branca RAL 9016
tinta de poliéster preta RAL 9005 - anodizado prateado
- Polias de material termoplástico anti-choque com rodas sobre
pernos de aço
- Sobreposição de resina acetálica autolubrificante de 7 cm
- Acessórios de resina acetálica autolubrificante



CARATTERISTICHE TECNICHE - SPECIFICATIONS CARACTERÍSTICAS - CARACTERÍSTICAS - CARACTÉRISTIQUES EIGENSCHAFTEN - KARAKTERISTIEKEN - ХАРАКТЕРИСТИКИ

- Profil en alliage d'aluminium extrudé 6060 T6 UNI 8278
- Largeur 18 mm - Hauteur 24,6 mm.
- Rail de coulissement: 6 mm.
- Rayon minimum - courbes à 90°: 12 cm
courbes à grand rayon: 50 cm.
- Finition superficielle:
peinture polyester blanc RAL 9016
peinture polyester noir RAL 9005; anodisé argent - or - bronze
- Poulies en matériau thermoplastique antichoc avec roues sur
pivots acier
- Croisement en résine d'acétal autolubrificante de 7 cm
- Accessoires en résine d'acétal autolubrificante

- Profil aus extrudierter Alu-Legierung 6060 T6 UNI 8278
- Breite 18 mm - Höhe 24,6 mm - Laufkanal: 6 mm
- Kleinster Biegeradius: 90°-Kurven: 12 cm mit großem Radius: 50 cm
- Oberflächen-Finish: Polyesterlackierung Weiß RAL 9016
Polyesterlackierung Schwarz RAL 9005
Alu eloxiert - Gold - Bronze
- Umlenkungen aus stoßfestem Thermoplast mit Rollen auf Stahlbolzen
- Überlappung aus selbstschmierendem Acetal 7 cm
- Zubehör aus selbstschmierendem Acetal

- 6060 T6 UNI 8278 geëxtrudeerd aluminium profiel
- Breedte 18 mm - hoogte 24,6 mm
- Kanaalbreedte 6 mm
- Minimum buigradius voor 90° verbuiging: 12 cm, voor grote
verbuiging: 50 cm
- Afwerking: RAL 9016 wit polyester lak, RAL 9005 zwart
polyester lak, zilver - goud - brons geanodiseerd.
- Schokbestendige thermoplastische poelies met wielen op metalen as
- Overlapbeugel 7 cm

- Профиль из экструдированного алюминиевого сплава
6060 T6 UNI 8278
- Ширина 18 мм - Высота 24,6 мм
- Желоб: 6 мм
- Минимальный радиус поворота на 90°: 12 см
повороты с большим радиусом: 50 см
- Отделка поверхности:
полиэфирная окраска в белый цвет RAL 9016
полиэфирная окраска в черный цвет RAL 9005
анодирование серебро
- Шкивы из противоударного термопласта с колесами на стальных осях
- Налегающий кронштейн из самосмазывающейся ацеталовой
пластмассы 7 см
- Принадлежности из самосмазывающейся ацеталовой пластмассы

INSTALLAZIONE

INSTALLATION
 INSTALACIÓN
 INSTALAÇÃO
 INSTALLATION
 INSTALLATION
 INSTALATIE
 УСТАНОВКА

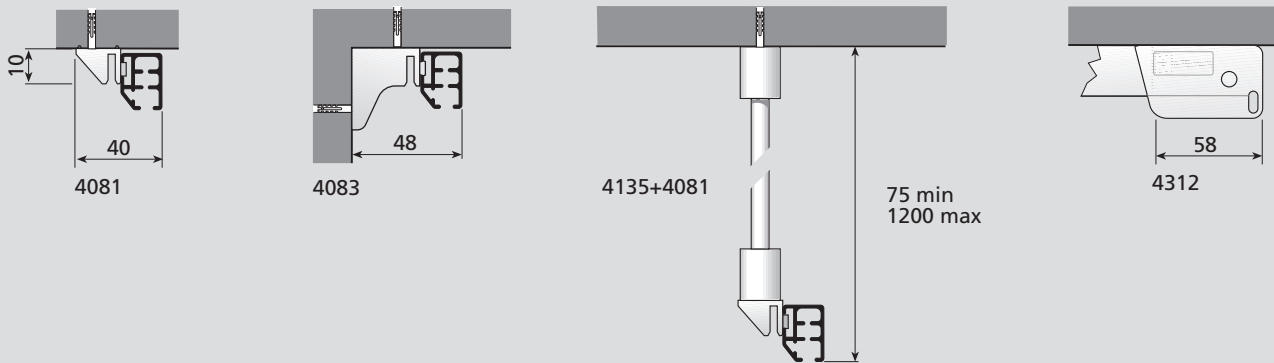
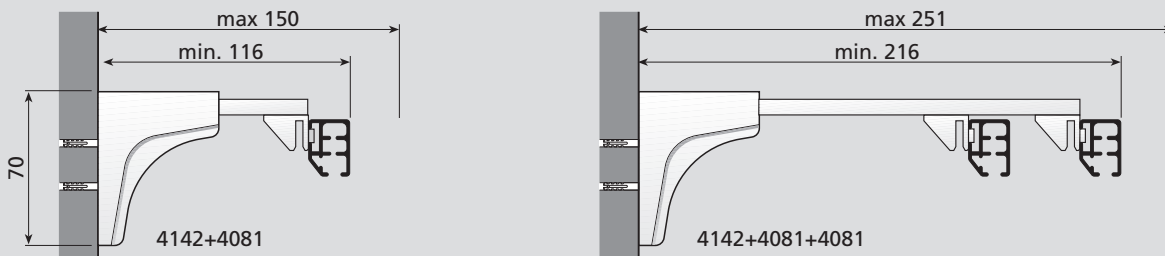
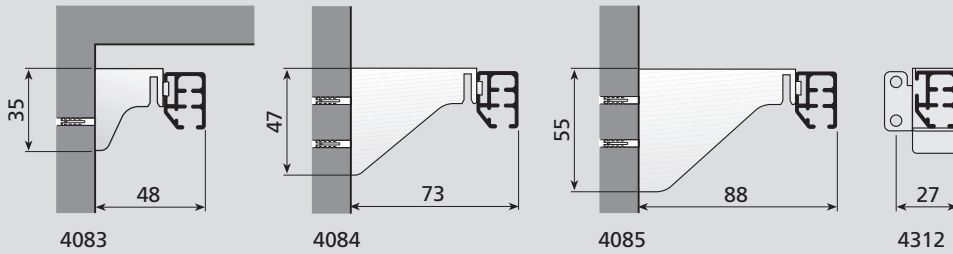

CURVE

BENDING
 CURVAS
 CURVAS
 COURBAGE
 BOGEN
 BUIGEN
 ИЗГИБ

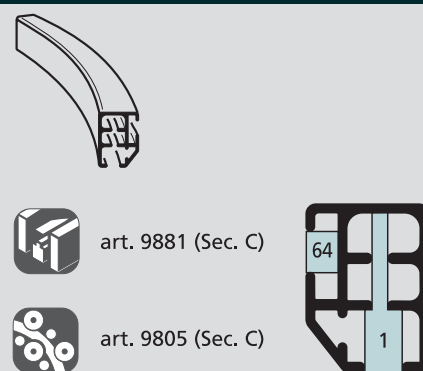
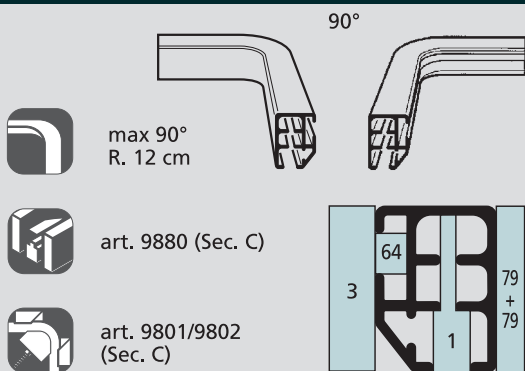

SISTEMAZIONI - APPLICATION - COLOCACIÓN - APLICAÇÕES - MONTAGE - MONTAGE - TOEPASSING - ВАРИАНТЫ УСТАНОВКИ

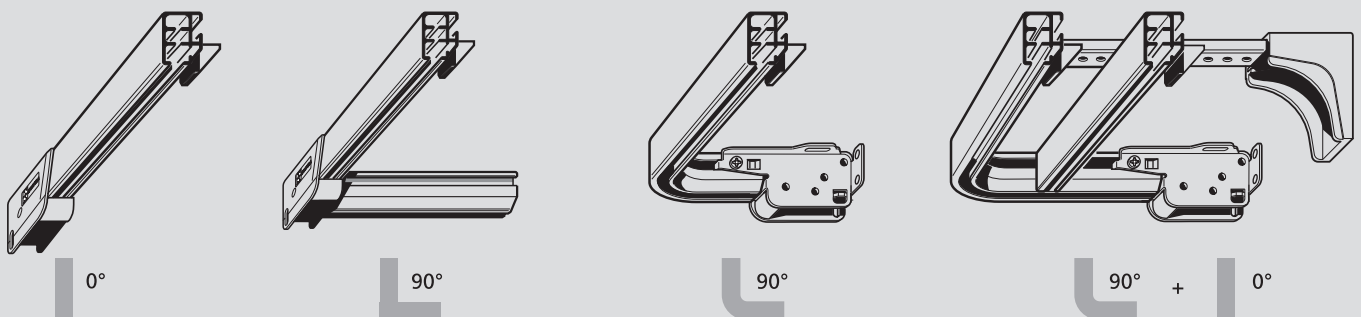



1.1.12

Arco_470

ROTTURA ALETTA DI FISSAGGIO

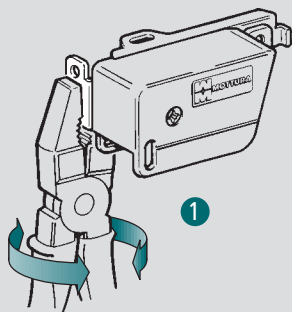

1

REMOVAL OF THE WALL
SUPPORT

COMO QUITAR EL SOPORTE
DE LA PARED

QUEBRA DA ASA DE
FIXAÇÃO

DES ENLÈVEMENT DU
SUPPORT MURAL

ENTFERNEN DES
WANDTRÄGERS

AFNEMEN VAN DE
WANDSTEUN

УДАЛЕНИЕ КРЕПЕЖНОГО
ЛЕПЕСТКА

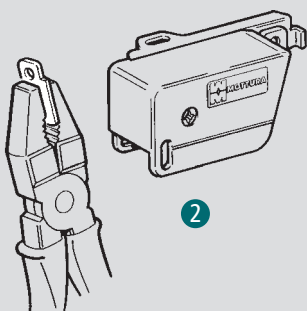

2

POSIZIONAMENTO SUPPORTI

SUPPORT POSITIONING

DISTANCIA ENTRE SOPORTES

POSIÇÃO DOS SUPORTES

POSITION DES SUPPORTS

ANBRINGUNG DER HALTERUNG

POSITIE VAN DE STEUNEN

РАЗМЕЩЕНИЕ КРОНШТЕЙНОВ

L cm	
140	1
141 → 200	2
201 → 280	3
281 → 340	4
341 → 480	5
481 → 600	6

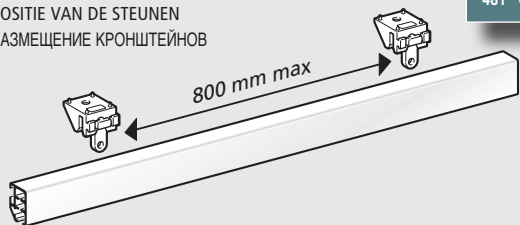

CARRUCOLA INTERMEDIA

INTERMEDIATE RETURN PULLEY

POLEA INTERMEDIA

POLIA CENTRAL

POULIE CENTRALE

ZWISCHENUMLENKER

CENTRALE POELIE

ЦЕНТРАЛЬНЫЙ БЛОК

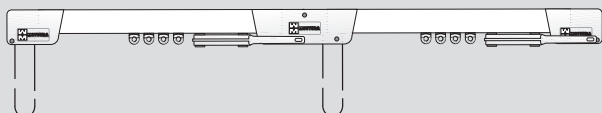
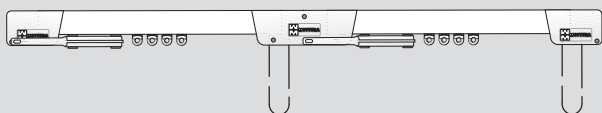
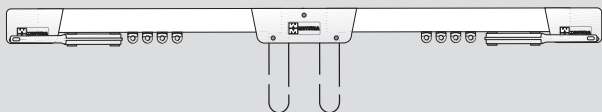







art. 4315

CONFEZIONI CONSIGLIATE

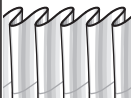
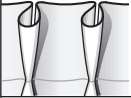
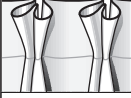
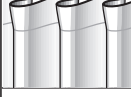
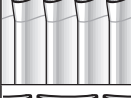
A RAPPORTO DI ARRICCIATURA
THE SPACE BETWEEN THE PLEATS
RAPPORT DE FRUNCIDO
RELAÇÃO DE FRANZIDO
INDIQUE LA DISTANCE ENTRE PLIS
GIBT DEN RAFFRAPPORT AN
GEEFT DE AFSTAND TUSSEN DE PLOOIEN AAN
ВИД ДРАПИРОВКИ

B NASTRO - TAPE
CINTA - FITA
GALON - BAND
LINT - ЛЕНТА

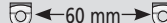
SUGGESTED STYLES OF CURTAINS
TIPOS DE CONFECCIÓN
TIPOS DE CORTINAS ACONSELHADOS
CONFECTION CONSEILLÉE
EMPFOHLENE VORHANGBÄNDER
AANBEVOLEN CONFECTIE
МОДЕЛЬ

	A	B
	1:2	art. 761 - h 70 mm
	1:1,5	art. 773 - h 90 mm art. 387
	1:2	art. 773 - h 90 mm art. 387
	1:2	art. 761 - h 70 mm
	1:2	art. 761 - h 70 mm
	1:3	art. 780 - h 90 mm art. 773 - h 90 mm art. 387
	1:3	art. 773 - h 90 mm art. 387
	2:3	art. 799 - h 75 mm
	4552/1 	
	4552/2 	

SCIVOLI

GLIDERS

CORREDERAS

DESLIZADORES

GLISSEURS

GLEITER

GLIJIDERS

БЕГУНКИ

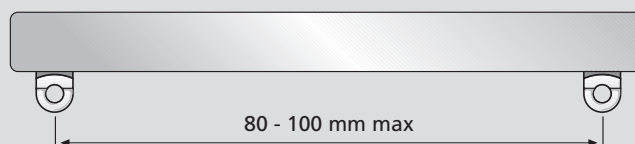

80 - 100 mm max

REGOLAZIONE CADUTA CORDA - CORD DROP ADJUSTMENT - REGULACIÓN CAÍDA CORDÓN - REGULAÇÃO DA QUANTIDADE DE CORDÃO CAÍDA
 RÉGLAGE DE LA RETOMBÉE DU CORDON - SCHNURFALLREGULIERUNG - AFSTELLING VAL VAN KOORD - РЕГУЛИРОВАНИЕ ВЫСОТЫ ВЕРЁВКИ

