

# Arco\_489

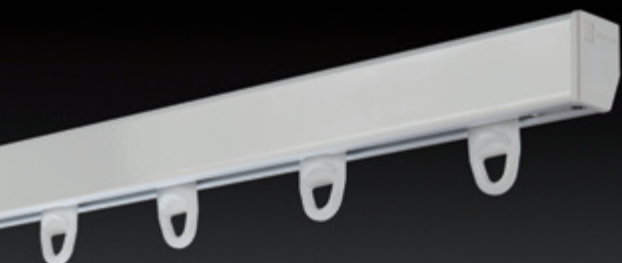

2.1.23

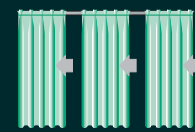

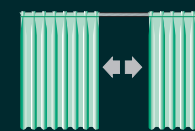
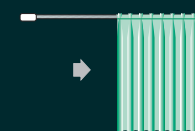
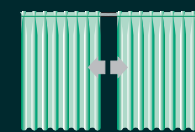

2.1.24

# Arco\_489

1:1

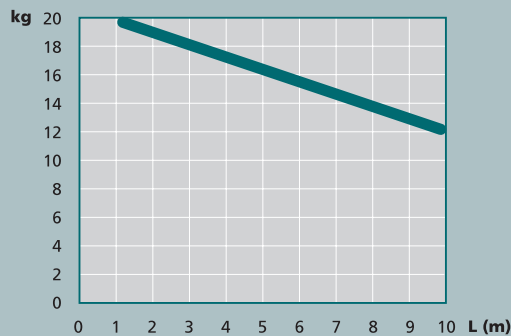
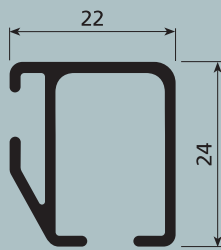
**USE**

UTILIZZO - USE - USO  
 USO - UTILISATION - ANWENDUNG  
 GEBRUIK - ИСПОЛЬЗОВАНИЕ

## SISTEMA PER TENDE ARRICCIATE PER AMBIENTI DOMESTICI O PROFESSIONALI

Azionamento a strappo indicato per tendaggi L 1000 cm max ed H 500 cm di peso non superiore a 12 kg.

L'apertura della tenda può essere centrale, laterale; (multipla o asimmetrica).

Il sistema è indicato per installazioni a soffitto ed a parete.

il sistema permette la realizzazione di sistemi curvi a 90° o centinati ad ampio raggio.

Per lo scorrimento il sistema utilizza:

- scorrevoli a rullo ref. 5017/5018 (6 kg max per 10 m - 489/1)
- scorrevoli a rullo ref. 5027/5028 (12 kg max per 10 m - 489/2).

## DRAPED CURTAIN SYSTEM FOR DOMESTIC OR PROFESSIONAL ENVIRONMENTS

Hand drawn operated. For use with curtains 1000 cm W max. and 500 cm H weighing not more than 12 kg.

The curtain opening can be central, lateral, multiple or asymmetric.

The system is suitable for ceiling and wall installation.

The system allows systems curved through 90° or with wide radius bended.

Sliding is guaranteed by:

- rollers ref. 5017/5018 (489/1 - 6 kg max per 10 m)
- rollers on ball bearings ref. 5027/5028 (489/2 - 12 kg max per 10 m).

## SISTEMA DE CORTINAS FRUNCIDAS PARA AMBIENTES DOMÉSTICOS O PROFESIONALES

Accionamiento manual. Adecuado para cortinas de anchura máx. 1000 cm y altura máx. 500 cm, de peso hasta 12 kg.

La apertura de la cortina puede ser central o lateral o múltiple o asimétrica.

Este sistema es adecuado para montajes en techo o en pared.

El sistema permite realizar instalaciones curvas de 90° o curvas de amplio ángulo.

El deslizamiento se efectúa mediante:

- Correderas con ruedas ref. 5017/5018 (489/1 - 6 kg max per 10 m)
- Correderas por rodamientos de bolas ref. 5027/5028 (489/2 - 12 kg max per 10 m).

## SISTEMA PARA CORTINAS FRANZIDAS PARA AMBIENTES DOMÉSTICOS OU PROFISSIONAIS

Accionamento à mão. Indicado para cortinas com largura máxima de 1000 cm, altura 500 cm e peso não superior a 20 kg.

A abertura da cortina pode ser central ou lateral ou múltipla ou assimétrica.

Este sistema é indicado para instalações no tecto e na parede.

Na utilização com accionamento à mão, o sistema permite fazer instalações com curvas de 90° ou curvaturas de raio amplo.

O deslizamento é garantido por

- corrediças ref. 5017/5018 (489/1 - 6 kg max per 10 m)
- corrediças sobre rolamentos de esferas ref. 5027/5028 (489/2 - 12 kg max per 10 m).

## SYSTÈME POUR RIDEAUX DRAPÉS À USAGE DOMESTIQUE OU PROFESSIONNEL

Actionnement par tirage manuel préconisé pour rideaux L 1000 cm Max et H 500 cm d'un poids maximum de 12 kg.

L'ouverture du rideau peut être centrale, latérale, multiple ou asymétrique.

Ce système est indiqué pour installation au plafond et de face.

Le système à tirage manuel permet la réalisation d'installations cintrées à 90° ou à grand rayon.

Le coulissement est assuré par:

- rouleurs en résine d'acétal ref. 5017/5018 (489/1 - 6 kg max per 10 m)
- rouleurs sur roulements à billes ref. 5017/5018 (489/2 - 12 kg max per 10 m)

## VORHANGSYSTEM FÜR DEN PRIVATEN HAUSHALT UND DEN ARBEITSBEREICH

Schleuderschiene. Für Gardinen mit max. L 1000 cm und H 500 cm.

Gewicht höchstens 12 kg.

Mögliche Öffnungsarten: 2-teilig, einteilig, mehrteilig oder asymmetrisch.

Das System ist für Decken- und Wandmontage geeignet.

Bei diesem System können 90°-Kurven oder Kurven mit großem Kurvenradius ausgeführt werden.

Selbstschmierende:

- Roller ref. 5017/5018 (- 489/1 höchstens 6 kg auf 10 m).
- Roller mit Kugellager ref. 5027/5028 (- 489/2 höchstens 12 kg auf 10 m).

## GORDIJNRAIL VOOR PRIVAAT EN PROFESSIONEEL GEBRUIK

Hand- of koordbediend. Gebruik voor gordijnen van maximum 5 m breed en 3 m hoog; maximum gordijngewicht 6 kg.

Openen van het gordijn kan centraal of lateraal; meerdere of asymmetrische verdeling enkel mogelijk met manueel bediening.

Bevestiging tegen plafond of wand. Met handbediening kan de rail op 90° of op grote straal verbogen worden. Enkel rechte installaties kunnen met koordbediening uitgerust worden.

Het glijden wordt gegarandeerd door :

- zelfsmerende polyethylene rollers ref. 5017/5018 (489/1 - 6 kg max per 10 m)
- rollers met kogellagers ref. 5017/5018 (489/2 - 12 kg max per 10 m)

## СИСТЕМА ДЛЯ ДРАПИРОВАННЫХ ШТОР, РЕКОМЕНДУЕТСЯ ДЛЯ БЫТОВЫХ И ОФИСНЫХ ПОМЕЩЕНИЙ

Система с ручным управлением. Рекомендуется для штор макс. длинна 1000 см и макс. высота 500 см с весом не более 12 кг.

Раздвижение центральное и боковое; (в нескольких точках или ассиметричное). Крепление стеновое и потолочное.

Возможно гнутье на 90° и широкий радиус.

Движение полотен осуществляется посредством:

- роликовые бегунки арт. 5017/5018 (для ткани весом не более 6 кг на каждые 10 м - 489/1)
- роликовые бегунки арт. 5027/5028 (для ткани весом не более 12 кг на каждые 10 м - 489/2)



CARATTERISTICHE TECNICHE - SPECIFICATIONS  
 CARACTERÍSTICAS - CARACTERÍSTICAS - CARACTÉRISTIQUES  
 EIGENSCHAFTEN - KARAKTERISTIEKEN - ХАРАКТЕРИСТИКИ

- Profilo in lega d'alluminio estrusa 6060 T6 UNI 8278
  - Larghezza 22 mm - Altezza 24 mm
  - Canale di scorrimento: 6 mm
  - Raggio di curvatura minima:  
curve a 90°: 12 cm;  
curve ad ampio raggio: 50 cm
  - Finiture superficiali:  
verniciatura poliester bianco RAL 9016;  
anodizzato argento
  - Sormonto in acetilica autolubrificante con asta in acciaio  
sino a 10 cm
  - Accessori in acetilica autolubrificante
- 6060 T6 UNI 8278 extruded aluminium alloy track
  - Width 22 mm - Height 24 mm
  - Sliding channel: 6 mm
  - Minimum radius of curvature:  
90° curves: 12 cm;  
wide radius curves: 50 cm
  - Surface finishes:  
RAL 9016 white polyester paint;  
silver
  - Self-lubricating acetylic overlap with steel rod up to 10 cm
  - Self-lubricating acetylic accessories
- Perfil en aleación de aluminio extruido 6060 T6 UNI 8278
  - Anchura 22 mm - Altura 24 mm
  - Canal de deslizamiento: 6 mm
  - Radio de curvatura mínima:  
curvas en 90°: 12 cm;  
curvas de ángulo amplio: 50 cm
  - Acabado de la superficie:  
pintura poliéster blanca RAL 9016;  
anodizado plata
  - Sobreposición de acetálico autolubrificante con asta de acero  
de hasta 10 cm
  - Accesorios de acetálico autolubrificante
- Perfil de liga de alumínio extrudido 6060 T6 UNI 8278
  - Largura 22 mm - Altura 24 mm
  - Calha de deslizamento: 6 mm
  - Raio de curvatura mínimo:  
curvas de 90°: 12 cm;  
curvas de raio amplo: 50 cm
  - Acabamentos superficiais:  
tinta de poliéster branca RAL 9016;  
anodizado prateado
  - Sobreposição de resina acetálica autolubrificante com  
haste de aço até 10 cm
  - Acessórios de resina acetálica autolubrificante



CARATTERISTICHE TECNICHE - SPECIFICATIONS  
 CARACTERÍSTICAS - CARACTERÍSTICAS - CARACTÉRISTIQUES  
 EIGENSCHAFTEN - KARAKTERISTIEKEN - ХАРАКТЕРИСТИКИ

- Profil en alliage d'aluminium extrudé 6060 T6 UNI 8278
  - Largeur 22 mm - Hauteur 24 mm
  - Rail de coulissement: 6 mm
  - Rayon minimum:  
courbes à 90°: 12 cm;  
courbes à grand rayon: 50 cm
  - Finition superficielle:  
peinture polyester blanc RAL 9016;  
anodisé argent.
  - Croisement en résine d'acétal autolubrifiante avec tige  
en acier jusqu'à 10 cm
  - Accessoires en résine d'acétal autolubrifiante.
- Profil aus extrudierter Alu-Legierung 6060 T6 UNI 8278
  - Breite 22 mm - Höhe 24 mm
  - Laufkanal: 6 mm
  - Kleinster Biegeradius: 90°;  
Kurven: 12 cm;  
Kurven mit großem Radius: 50 cm
  - Oberflächen-Finish:  
Polyesterlackierung Weiß RAL 9016;  
Alu eloxiert
  - Überlappung aus selbstschmierendem Acetal mit Stahlstab  
bis 10 cm
  - Zubehör aus selbstschmierendem Acetal
- 6060 T6 UNI 8278 geëxtrudeerd aluminium profiel
  - Breedte 22 mm - hoogte 24 mm
  - Kanaalbreedte 6 mm
  - Minimum buigradius voor 90° verbuiging: 12 cm voor grote  
verbuiging: 50 cm
  - Afwerking: RAL 9016 wit polyester lak, zilver geanodiseerd.
  - Overlapbeugel tot 10 cm
  - Accessoires in zelfsmierend acetal
- Профиль из экструдированного алюминиевого сплава  
6060 T6 UNI 8278
  - Ширина 22 мм - Высота 24 мм
  - Желоб: 6 мм
  - Минимальный радиус поворота:  
повороты 90°: 12 см;  
повороты с большим радиусом: 50 см
  - Отделка поверхности:  
полиэфирная окраска в белый цвет RAL 9016;  
анодирование серебро
  - Налегающий кронштейн из самосмазывающейся ацеталовой  
пластмассы со стальной штангой длиной до 10 см
  - Принадлежности из самосмазывающейся ацеталовой  
пластмассы



2.1.26

# Arco\_489

## INSTALLAZIONE

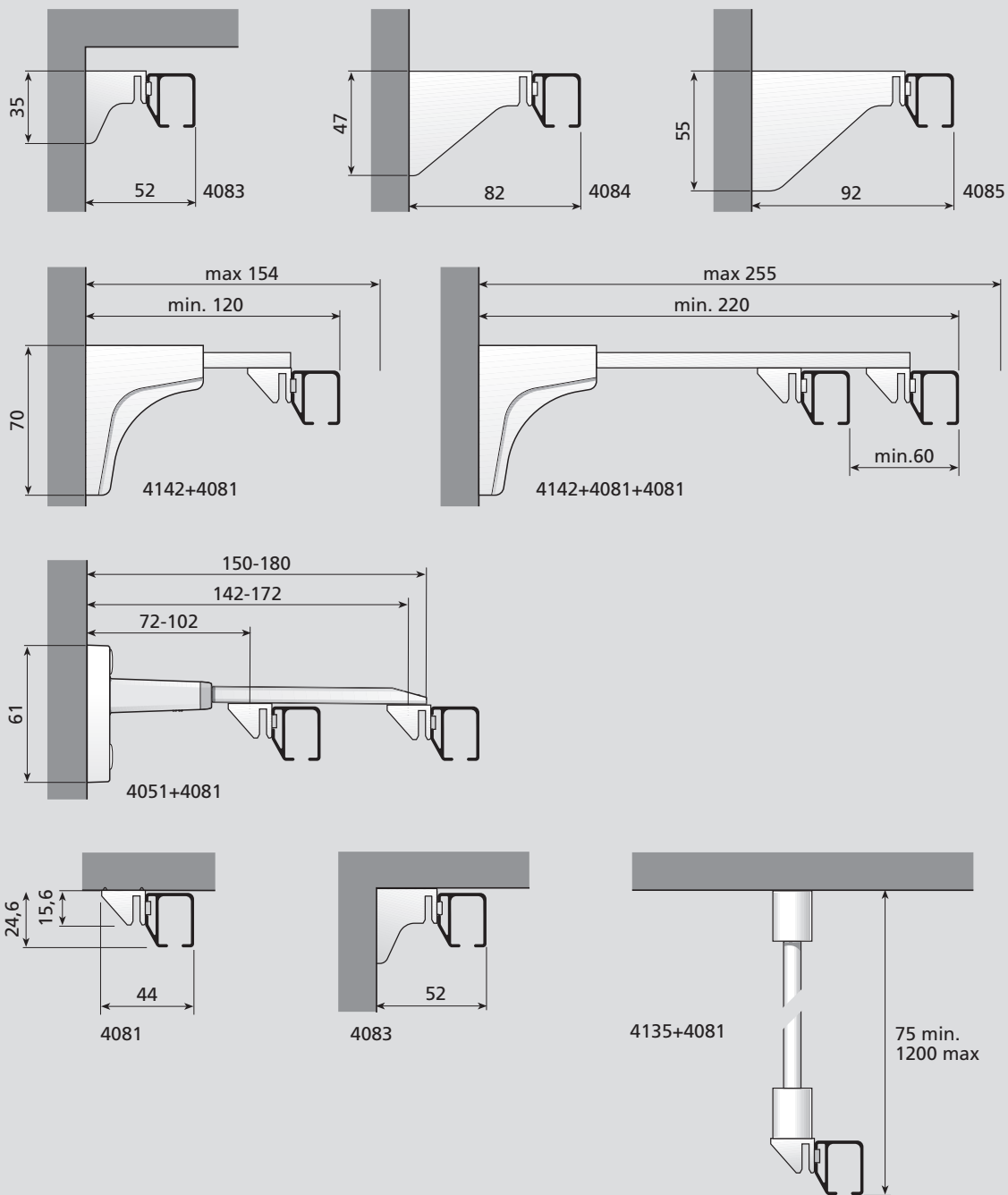

INSTALLATION  
 INSTALACIÓN  
 INSTALAÇÃO  
 INSTALLATION  
 INSTALLATION  
 INSTALLATIE  
 УСТАНОВКА

## CURVE

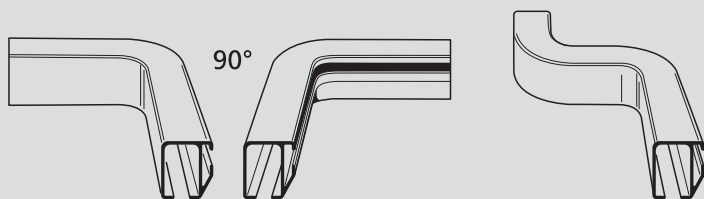

90°



max 90°  
R. 12 cm



art. 9866 (Sec. C)



art. 9801-9802  
(Sec. C)

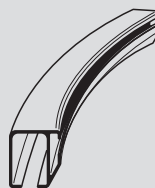
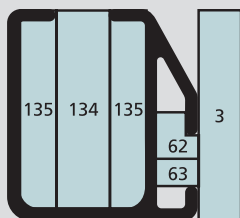

BENDING  
 CURVAS  
 CURVAS  
 COURBAGE  
 BOGEN  
 BUIGEN  
 ИЗГИБ



art. 9867 (Sec. C)



art. 9805 (Sec. C)

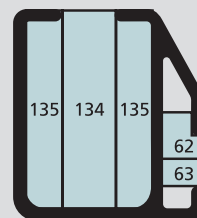

## SORMONTO

5327

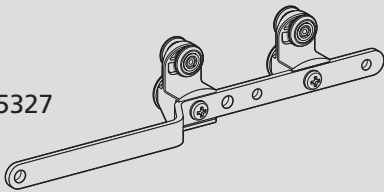

OVERLAP  
CRUCE  
SOBREPOSIÇÃO  
CONDUCTEUR DE  
RECOUVREMENT  
ÜBERLAUFWAGEN  
OVERLAP BEUGEL  
НАЛЕГАЮЩИЙ  
КРОНШТЕЙН



5028



5027



5018



5017

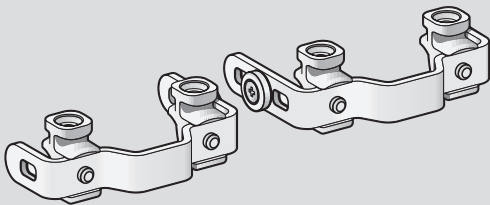

4604

4605

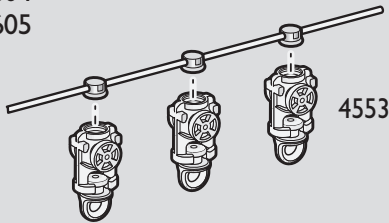

4553

## POSIZIONAMENTO SUPPORTI

SUPPORT POSITIONING  
DISTANCIA ENTRE SOPORTES  
POSIÇÃO DOS SUPORTES  
POSITION DES SUPPORTS  
ANBRINGUNG DER  
HALTERUNG  
POSITIE VAN DE STEUNEN  
РАЗМЕЩЕНИЕ КРОНШТЕЙНОВ

L cm	
140	1
141 → 200	2
201 → 280	3
281 → 340	4
341 → 480	5
481 → 600	6

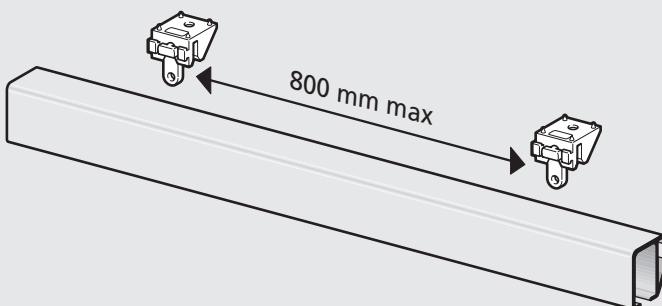

## CONFEZIONI CONSIGLIATE

**A** RAPPORTO DI ARRICCIATURA  
THE SPACE BETWEEN THE PLEATS  
RAPPORT DE FRUNCIDO  
RELAÇÃO DE FRANZIDO  
INDIQUE LA DISTANCE ENTRE PLIS  
GIBT DEN RAFFRAPPORT AN  
GEEFT DE AFSTAND TUSSEN DE PLOOIEN AAN  
ВИД ДРАПИРОВКИ

**B** NASTRO - TAPE  
CINTA - FITA  
GALON - BAND  
LINT - ЛЕНТА

SUGGESTED STYLES OF CURTAINS  
TIPOS DE CONFECCIÓN  
TIPOS DE CORTINAS ACONSELHADOS  
CONFECTION CONSEILLÉE  
EMPFOHLENE VORHANGBÄNDER  
AANBEVOLEN CONFECTIE  
МОДЕЛЬ

	A	B
	1:2	art. 761 - h 70 mm art. 775 - h 65 mm art. 776 - h 80 mm art. 795/... - h 80 mm
	1:1,5	art. 773 - h 90 mm art. 387
	1:2	art. 773 - h 90 mm art. 387
	1:2	art. 761 - h 70 mm art. 776 - h 80 mm art. 795/... - h 80 mm
	1:2	art. 761 - h 70 mm art. 776 - h 80 mm art. 795/... - h 80 mm
	1:3	art. 780 - h 90 mm art. 773 - h 90 mm art. 387
	1:3	art. 773 - h 90 mm art. 387
	2:3	art. 799 - h 75 mm
	4553/1 ← 60 mm →	
	4553/2 ← 80 mm →	

## SCIVOLI

GLIDERS  
CORREDERAS  
DESILIZADORES  
GLISSEURS  
GLEITER  
GLIDERS  
БЕГУНКИ

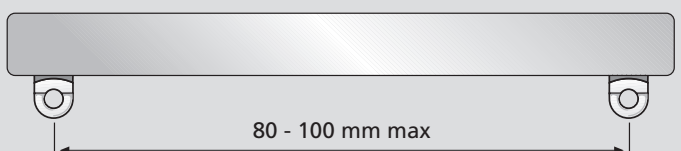





2.1.28

# Arco\_489

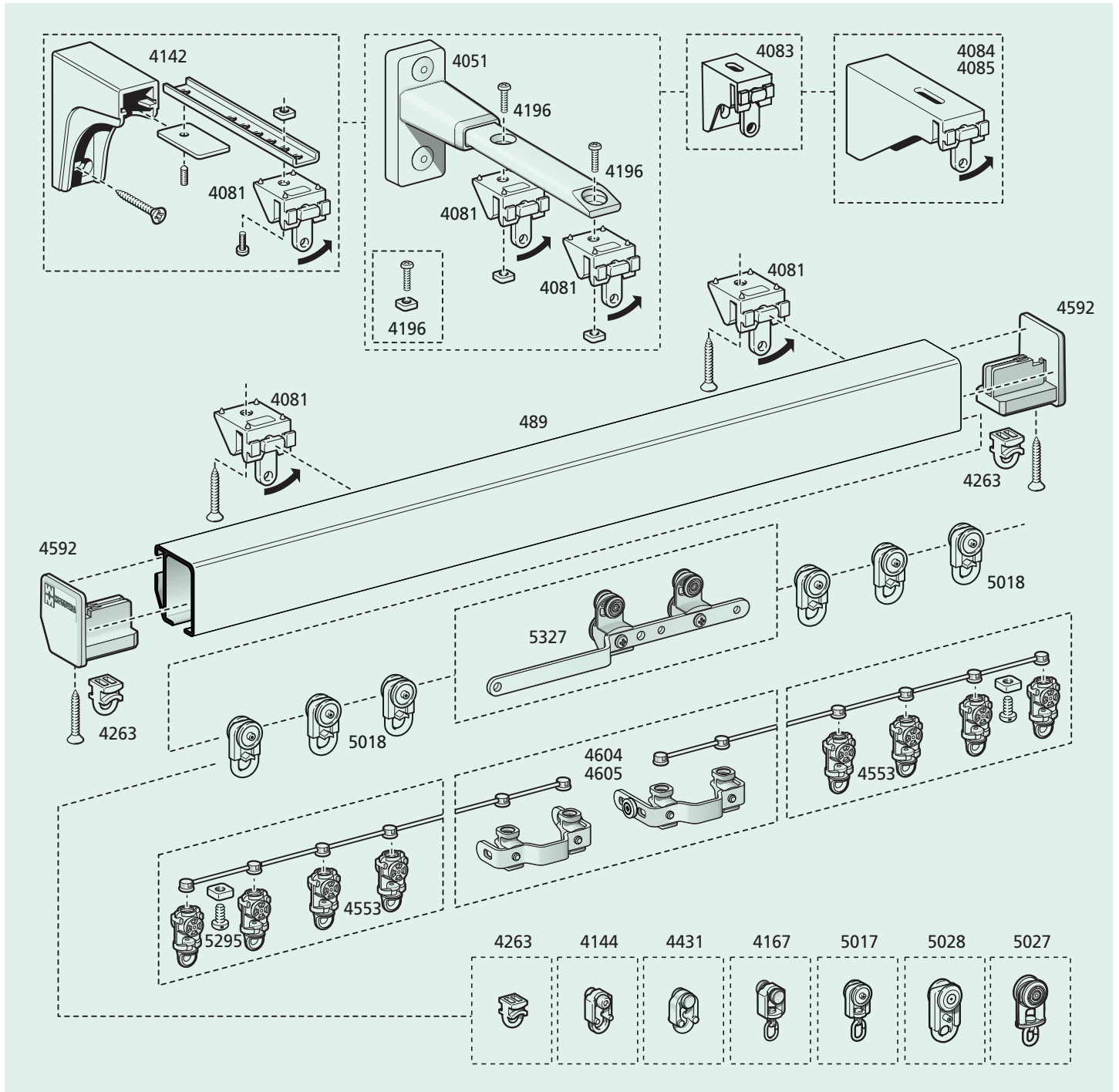

SISTEMAZIONI - APPLICATION - COLOCACIÓN - APLICAÇÕES - MONTAGE - MONTAGE - TOEPASSING - ВАРИАНТЫ УСТАНОВКИ

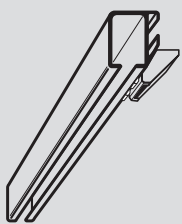

0°

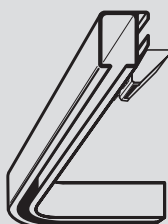

90°

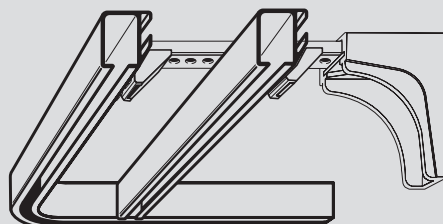

90° + 0°

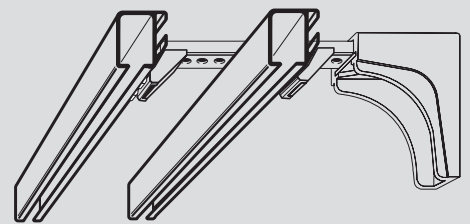

0° + 0°